

Hanger Welding Specifications for Leaf Spring Axles

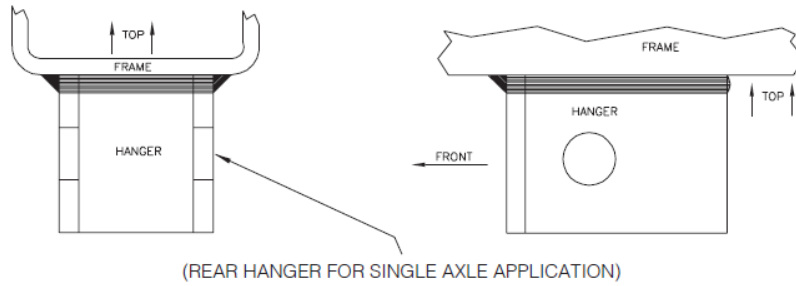
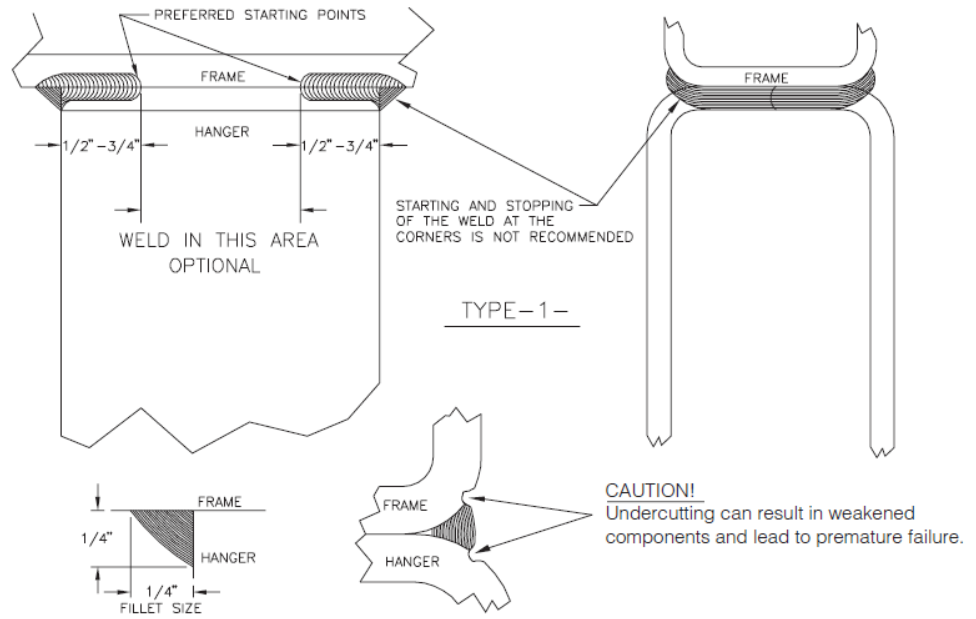
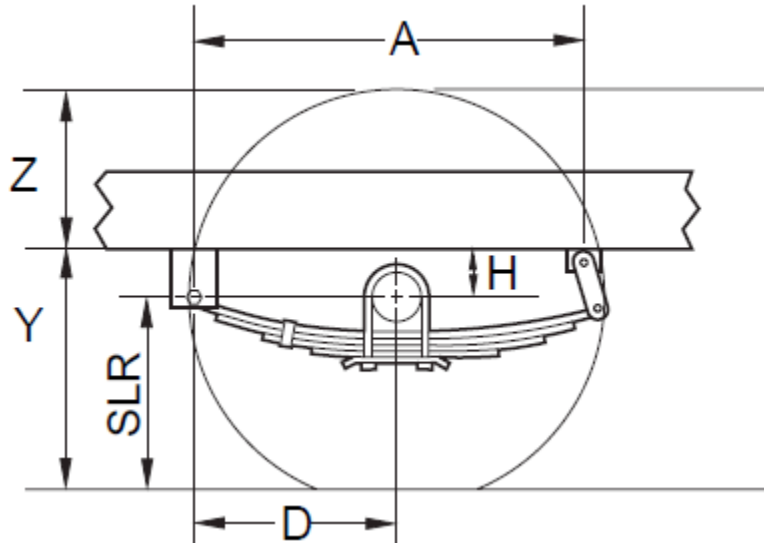

Fig. 1



Single Axle Spring Hanger Bracket Spacing



A = 25.75" for Std 26" Spring

Tandem Axle Spring Hanger Bracket Spacing (35" on Center)

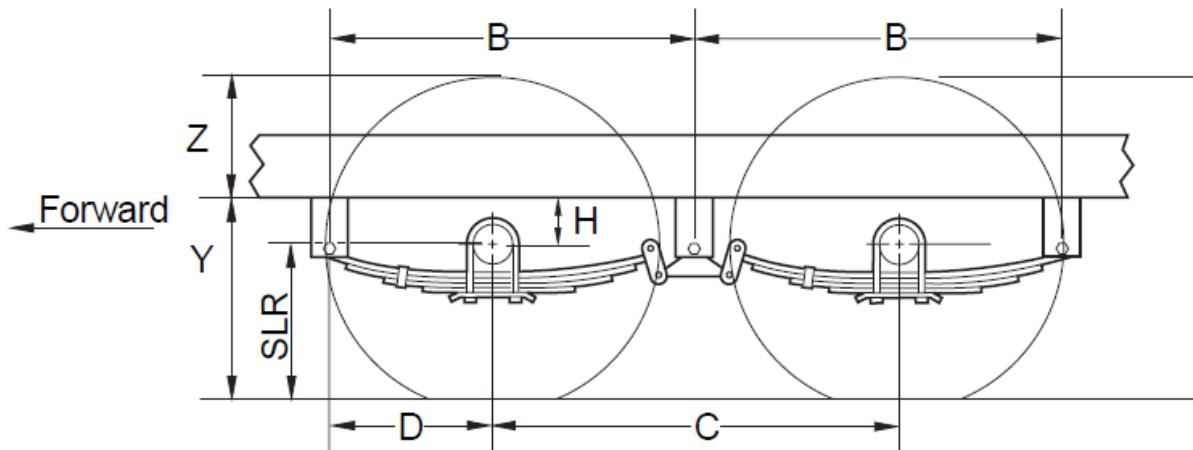

B = 30.50" for Std 26" Spring & 35.00" Axle Spacing (C)